



RST410
Gateway configuration guide

Contents

Overview	3
Configuration	4
Serial Port I/O PIN	4
Manual acknowledgement of duress	5
Configuration command	5
Wiring diagram	5
ACK line handling	6

Overview

This document is designed to explain the configuration and implementation of the manual acknowledgment of the duress alarm.

In normal condition, RST410 uses the auto acknowledgment method for duress. When the duress is triggered from the Pendant, the gateway will send an auto response to the Pendant to give user acknowledgment of the duress. However it is possible to configure the gateway to provide acknowledgment to Pendant only upon external input. This document explains the commands and wiring to use the manual acknowledgment method.



Configuration

The Gateway supports AT style commands (AT^) for configuration. These commands can be entered using a windows terminal program such as HyperTerminal®. A “null-modem” cable is required to enable communications between a PC/laptop and the Gateway. In order to save the configuration, AT&W command must be used. Configuration will be lost after a power cycle if the configuration is not saved

Serial Port I/O PIN

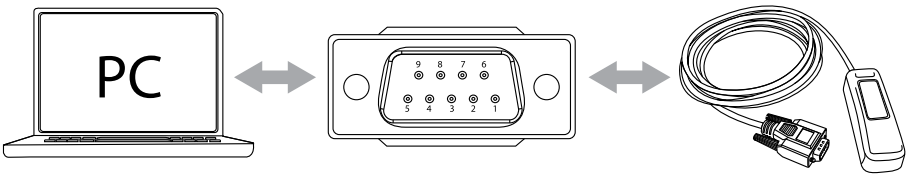

Null modem I/O PIN configuration

DB9 Pin	Signal	Name	Direction
1	DCD	Data Carrier Detect	Serial Modem → Gateway
2	RxD	Received Data (by DTE)	Serial Modem → Gateway
3	TxD	Transmitted Data (by DTE)	Gateway → Serial Modem
4	DTR	Data Terminal Ready	Gateway → Serial Modem
5	GND	Signal Ground	
6	DSR	Data Set Ready	Serial Modem → Gateway
7	RTS	Request To Send	Gateway → Serial Modem
8	CTS	Clear To Send	Serial Modem → Gateway
9	RI	+ 3.9 V	Serial Modem → Gateway

Manual acknowledgement of duress

When using manual acknowledgment, ACK line on gateway relay interface is used to detect and provide acknowledgement back to pendant.

Configuration commands

Step #	Command	Description
1	AT^DTRAUTOACK=n	When PANIC is received, ACK line 102 is used to detect acknowledgement
2	AT^DTRPANICTIMEOUT=n Where n is the number of seconds (0-65535) n=0 disables the timeout default value is 60	If this timeout is set, panic indicating state of the Gateway will be reset automatically if no communication is detected from the panic state triggering Man Down Pendant.
3	AT&W	Save settings

Wiring diagram for Gateway Relay Interface

DB9 Pin	Signal Name	Direction
100	VIN	Power supply Input 5-26V
101	GND	Power Ground
102	ACK	Panic Acknowledgement input
103	PANIC IN	Common contact for PANIC state controlled relay
105	PANIC OUT NC	Normally closed contact for PANIC state controlled relay
109	#Sleep	Sleep Input. Pull to VIN to keep avoid unit going to low power mode



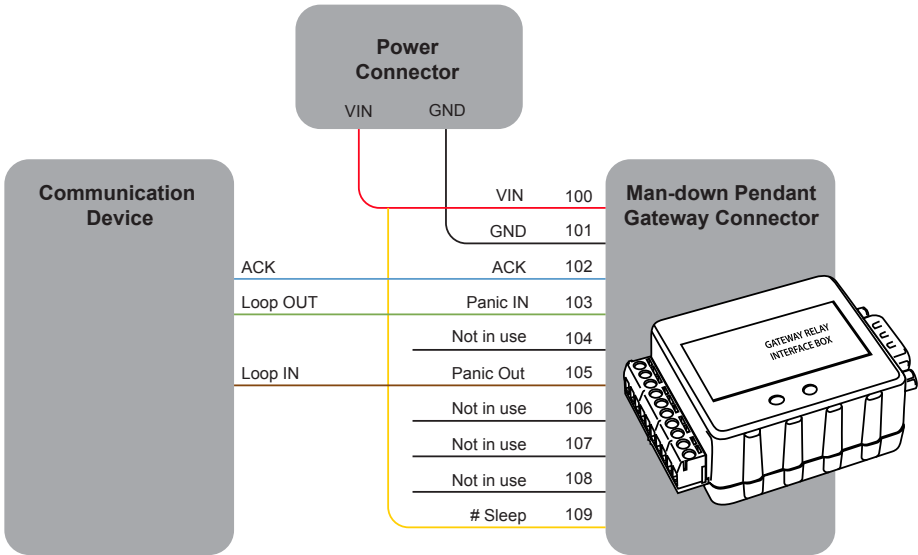

ACK line handling

ACK line must be supplied with +3V in normal operation. In order to acknowledge the PANIC, the ACK input needs to be pulled negative to below -3V.

Operation mode	ACK line
Normal mode	+3V
Panic acknowledgement	-3V

Panic Generation Sequence Diagram

User initiates a "PANIC" alert by pressing and holding (for >3 seconds) the panic button until both LED's blink green and orange

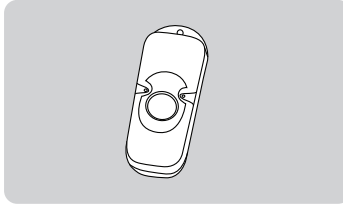

Pendant sends "Panic alert" to the Gateway



Gateway receives the "Panic alert" from the Pendant

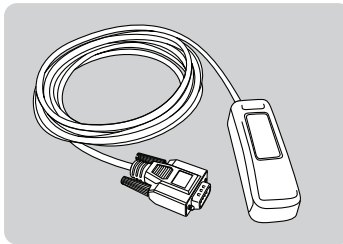

Gateway Relay Interface breaks the loop

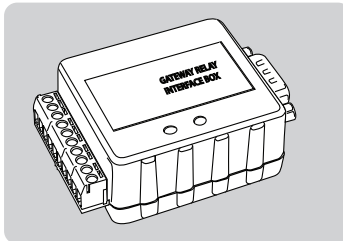

The outputs of the Relay Interface's relay change states



Panic Acknowledgement Sequence Diagram

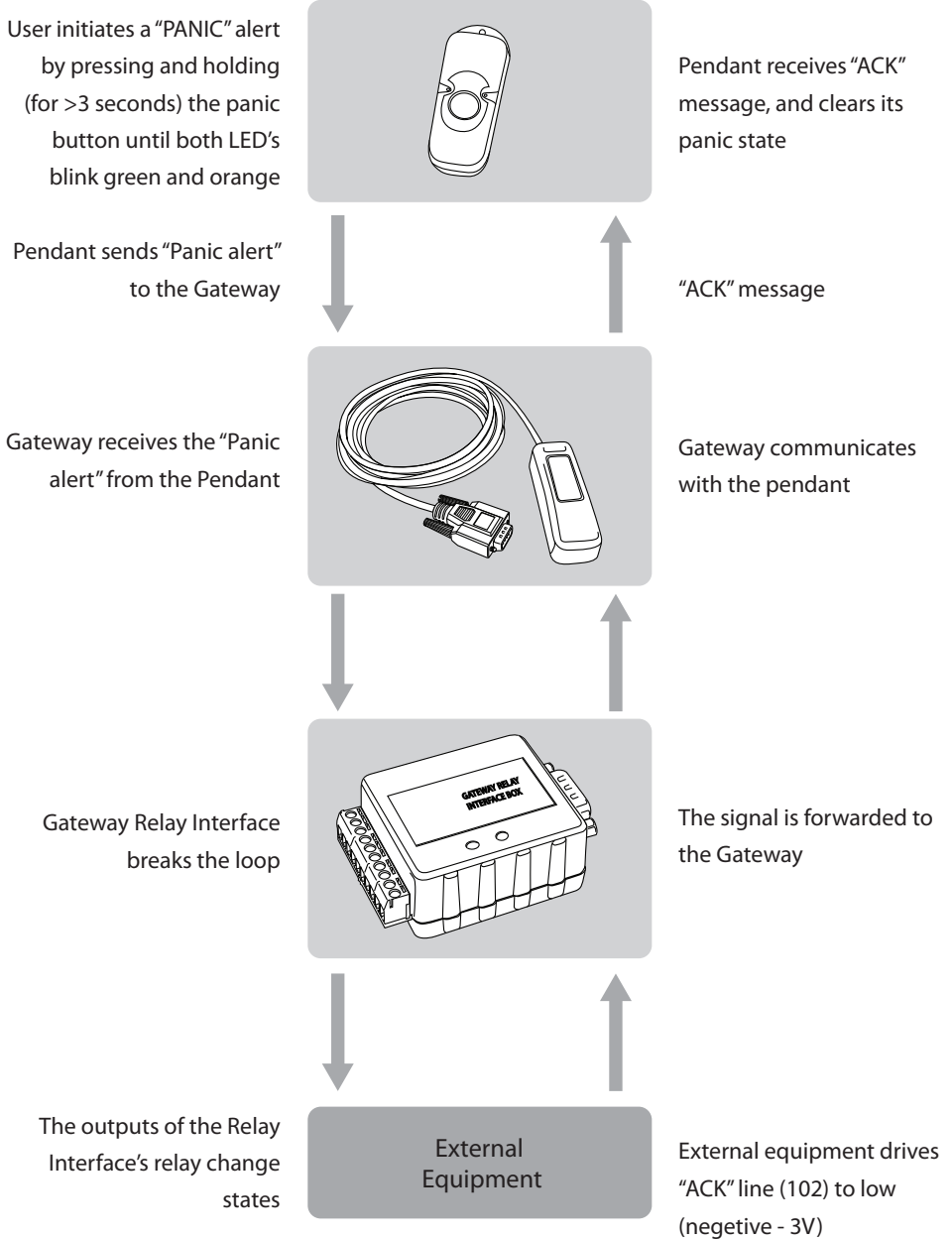

This page has been left blank intentionally



This page has been left blank intentionally

This page has been left blank intentionally





GLOBAL HEAD OFFICE

8 Anzed Court
Mulgrave, Victoria,
Australia, 3170

Tel: +61 3 8588 4500 | Fax: +61 3 9560 9055

AMERICAS

Tel: +1 954 376 5062

EUROPE

Tel: +44 208 144 1405 | Fax: +44 208 289 3542

Sales | sales@beamcommunications.com

General | info@beamcommunications.com

Support | support@beamcommunications.com