



IsatDock **DRIVE**



User Manual

Beam IsatDock DRIVE

Installation and User Manual

Product name: IsatDock DRIVE

Manual revision: 05

Part Number: USRMAN006005

Release date: April 2017

Beam Communications Pty Ltd
5/8 Anzed Court, Mulgrave,
Victoria, 3170, AUSTRALIA

Information furnished by Beam Communications Pty Ltd (Beam) is believed to be accurate and reliable. However, no responsibility is assumed by Beam for its use, or for any infringement of patents or other rights of third parties, which may result from its use. No license is granted by implication or otherwise under any patent or patent rights of Beam. Beam reserves the right to change specifications at any time without notice.

Copyright © 2010 Beam Communications Pty Ltd. All rights reserved

About Beam Communications

Beam Communications, a wholly owned subsidiary of World Reach Limited (WRR), listed on the Australian Stock Exchange, is a world leader in design, manufacture and distribution of specialised communications equipment for the Inmarsat Satellite Network.

Beam's commitment to be at the forefront has continued to increase its share of the global satellite communications market. Its premium distribution network spans the world.

Recognized as a leading provider of satellite communication solutions, **Beam** specializes in Voice, Data, Tracking and customized solutions. **Beam** develops innovative products and services to meet market demands and niche applications.

Beam's leading edge products are deployed in a wide range of vertical markets including Maritime, Transport, Government, Defence, Mining, Construction, Forestry, Emergency Services, Relief Aid, Telemetry and Rural Telephony.

Supported by a dedicated team of professionals, **Beam** has developed solid relationships with its peers and network of distributors worldwide.



Beam Communications Pty Ltd

5/8 Anzed Court, Mulgrave,
Victoria, 3170, AUSTRALIA

Web: www.beamcommunications.com
Information: info@beamcommunications.com
Support: support@beamcommunications.com

Tel: +61 3 8588 4500
Fax: +61 3 9560 9055

Conventions in this Manual

These notes will appear throughout this manual and should be taken into consideration.



Warning or Caution

This symbol and associated text indicate a warning note providing information to prevent damage to equipment or personal injury.



Note/Important/Tip Header

This symbol and associated text indicate a note providing general operating information.



Interference Header

All wireless phones may get interference, which could affect performance.



Record Header

Write details of your unit for easy reference when required. Ideal when troubleshooting.

Terminology

TERM	DESCRIPTION
Falcon	Falcon Configuration Tool - MS Windows Install
SMS	Short Message Service
Mobile Originating	Describes a call initiated by the IsatDock
Mobile Terminating	Describes an incoming call being answered by the IsatDock
IsatPhone Pro	The Inmarsat IsatPhone Pro handset
®	The ® symbol, mark and logos are owned by the respective companies of which the symbol follows. Any use of such marks by Beam Communications is under license. Other trademarks and trade names are those of their respective owners.
RF	Radio Frequencies
SMA	Sub Miniature version A co-axial RF connection
RJ9	4P4C connector for the privacy handset
GPS	Global Positioning System
GSPS	Inmarsat's Global Satellite Phone Service

Package Contents

Check that your IsatDock DRIVE package contains all of the following items:

- 1 x IsatDock DRIVE docking station
- 1 x DC Power Cable / Lead
- 1 x Universal Mounting Bracket (RAM)
- 3 x M4 Screws and washers
- 1 x Fuse Kit
- 2 x Handset Locking Keys
- 1 x Speaker
- 1 x Microphone
- User Manual
- Quick Start Guide

Falcon Configuration Tool
is available for download from:

[www.beamcommunications.com/support/
drive](http://www.beamcommunications.com/support/drive)

Optional Accessories

The following optional accessories are available for your IsatDock DRIVE

Active Antennas

- ISD715 Transport Magnetic Antenna (Active)
- ISD720 Transport Bolt Antenna (Active)

Antenna Cable Kits for Active Antennas

- ISD932 6m cable kit (Active)
- ISD933 13m cable kit (Active)
- ISD934 18m cable kit (Active)
- ISD935 31m cable kit (Active)
- ISD938 40m cable kit (Active)
- ISD942 50m cable kit (Active)
- ISD943 60m cable kit (Active)
- ISD944 70m cable kit (Active)
- ISD945 80m cable kit (Active)
- ISD946 90m cable kit (Active)
- ISD947 100m cable kit (Active)

Additional Accessories

- ISD955 Privacy Handset
- ISD951 110-240v AC plug pack
- RST055 UPS Battery Pack

See your service provider for pricing and availability of these quality Beam accessories.

Additional Information

For the latest in supporting software and documentation for IsatDock DRIVE please contact www.beamcommunications.com/support/drive

Alert / Tracking

To configure the alert / tracking functionality on your IsatDock DRIVE, you must first install the Falcon software, which also includes the Beam USB drivers for Microsoft Windows based operating systems.

Other Resources Available Online

- Advanced Configuration – in-built to Falcon
- Quick Start Guide & Manual
- Antenna Installation Guide
- IsatPhone Pro firmware upgrade if required

CONTENTS

IsatDock DRIVE Part Number	2	IsatDock DRIVE Key Features	11	USB Driver Installation	
About Beam Communications	3	Tracking/Alert Monitoring		Tracking and Alert Operations	
Conventions in this Manual	4	Configuration Using Falcon		IsatDock DRIVE Front Panel	
Terminology		Configuration Using Remote Commands		IsatDock DRIVE Buttons/LED lights	
Package Contents	5	Equipment Overview	13	Assuring Quality of Service	
Optional Accessories		Installation Guidelines	14	Specification Summary	28
Additional Information		Routing Cables (for vehicle installations)		Electrical & Environmental Specifications - IsatDock DRIVE	
Alert/Tracking		Guidelines for Electrical Connections		(1) Physical Dimensions - DRIVE Dock	
Other Resources Available Online		Installation Procedure	15	(2) Physical Dimensions - Privacy Handset	
Safety Information	7	Installing the IsatDock DRIVE Cradle		Trouble Shooting	30
Safety Transceiver IsatPhone Pro		IsatDock DRIVE Usage	21	Beam Warranty Terms & Conditions	31
IsatDock FCC Information		Docking & undocking the IsatPhone Pro handset			
Electronic Devices		Operation of the IsatPhone Pro			
Pacemakers		Placing Voice Calls			
Other Medical Devices		Privacy Handset Use (Optional Accessory)			
Vehicles		Mute Mode			
Posted Facilities					
Aircraft					
Vehicles Equipped with an Air Bag					

Safety Information



IMPORTANT!

Please read the following information carefully before installing and using the IsatDock DRIVE.

Failing to follow instructions may compromise the safety of the product and may result in personal injury and/or equipment damage. Please consult your supplier if you have any further questions.

The IsatDock DRIVE is a low power docking station for the IsatPhone Pro handset. When ON, it will charge the IsatPhone Pro handset whilst docked in the IsatDock DRIVE.

Refer to the appropriate section of this IsatDock DRIVE Installation & User Manual for additional safety information.

- Store the system in a cool and dry area.
- Do not submerge the system in water.
- Do not place foreign metal objects or debris in the system. If debris enters into the system, please return to factory for service.



WARNING

DO NOT open equipment. There are no user-serviceable parts inside.

If a DC power supply is to be used, its output must comply with the Safety Extra Low Voltage (SELV) requirements of IEC60950.

All connectors must only be connected to equipment ports which comply with the Safety Extra Low Voltage (SELV) requirements of IEC60950.

POTENTIALLY EXPLOSIVE ATMOSPHERES

- Turn your phone OFF and DO NOT remove your battery or remove the IsatPhone Pro handset from the cradle when you are in any area with a potentially explosive atmosphere.
- Obey all signs and instructions.
- Sparks from your battery in such areas could cause an explosion or fire resulting in bodily injury or even death.

- Areas with a potentially explosive atmosphere are often but not always clearly marked. They include, but are not limited to:
 - » fuelling areas such as gasoline stations
 - » below deck on boats;
 - » fuel or chemical transfer or storage facilities;
 - » areas where fuel odors are present (for example, if a gas/propane leak occurs in a car or home);
 - » areas where the air contains chemicals or particles, such as grain, dust, or metal powders;
 - » any other area where you normally would be advised to turn off your vehicle engine.

Safety transceiver IsatPhone Pro

Your handset is a low power radio transmitter and receiver. When it is ON, it receives and also sends out radio frequency (RF) signals.

(NOTE: Refer to Inmarsat IsatPhone Pro Manual for additional Information)

- The Inmarsat IsatPhone Pro handset has an in-built transceiver which is designed to be used with an external antenna. This antenna transmits RF energy. The Beam antenna (fitted via an extension coaxial cable to the cradle) must be located more than > 55cm from the human body (person) when in operation.
- International agencies have set standards and recommendations for the protection of public exposure to RF electromagnetic energy. These standards are based on extensive scientific review by scientists, engineers, and physicians from universities, government health agencies, and industry groups. They review the available body of research to develop ANSI standard. These ANSI standards are reviewed regularly for research development.

- » International Commission on Non-Ionizing Radiation Protection (ICNIRP) 1996
- » Verband Deutscher Elektrotechniker (VDE) DIN-0848
- » United States Federal Commission, Radio Frequency Exposure Guidelines (1996)
- » National Radiological Protection Board of the United Kingdom, GS 11, 1988
- » American National Standards Institute (ANSI) IEEE. C95. 1-1992
- Do not operate your satellite telephone when a person is within 55cm of the antenna. A person or object within 55cm of the antenna could impair call quality and may cause the phone to operate at a higher power level than necessary and expose that person to RF energy in excess of that established by the FCC RF Exposure Guidelines.
- As a precaution, please maintain the maximum body distance possible from the antenna during call transmission.



WARNING

ROAD SAFETY COMES FIRST!

Do not use a hand-held cellular terminal, satellite phone or mobile when driving a vehicle, unless it is securely mounted in a holder for speaker phone operation. Before making a call with a handheld terminal, satellite phone or mobile, park the vehicle stationary. Please obey local road laws for hands-free speakerphone operation. Speakerphones (hands-free) must be installed by qualified personnel. Faulty installation or operation can constitute a safety hazard.



IMPORTANT

Cellular & Satellite terminals or mobiles operate using radio signals and communication networks. Because of this, the connection cannot be guaranteed at all times or under all conditions. Therefore, you should never rely solely upon any wireless device for essential communications, for example emergency calls.

IsatDock FCC Information

This equipment has been tested and found to comply with the limits for a Class B digital devices, pursuant to Part 15 of the FCC Rules. These limits are designed to provide reasonable protection against harmful interference in a residential installation. This equipment generates, uses, and can radiate radio frequency energy and, if not installed and used in accordance with the instruction manual, may cause harmful interference to radio communications. However, there is no guarantee that interference will not occur in a particular installation. If this equipment does cause harmful interference to radio or television reception, which can be determined by turning the equipment off and on, the user is encouraged to try to correct the interference by one or more of the following measures:

- Reorient or relocate the receiving antenna
- Increase the separation between the equipment and receiver
- Connect the equipment into an outlet on a circuit different from that to which the receiver is connected.
- Consult the dealer or an experienced radio/TV technician for help.

This device has been designed to operate with, ISD715/ISD720 AT1595-83 and having a maximum gain of 6dBi Antennas having a gain greater than 6dBi are strictly prohibited for use with this device.

To reduce potential radio interference to other users, the antenna type and its gain should be so chosen that the equivalent isotropically radiated power (EIRP) is not more than that required for successful communication



WARNING

Changes or modifications not expressly approved by Beam Communications could void the product warranty.

Electronic Devices

Most modern electronic equipment is shielded from RF signals. However, certain equipment may not be shielded against the RF signals from your wireless phone.

Pacemakers

The Health Industry Manufacturers Association recommends that a minimum separation of six inches (6") be maintained between a wireless phone's antenna and a pacemaker to avoid potential interference with the pacemaker. These recommendations are consistent with the independent research by and recommendations of Wireless Technology Research.

Persons with pacemakers:

- *Should ALWAYS keep the phone more than six inches from their pacemaker when phone is turned ON.*
- *Should turn the phone OFF immediately if you have any reason to suspect interference is taking place.*

Other Medical Devices

If you use any other personal medical device, consult the manufacturer of your device to determine if it is adequately shielded from external RF energy. Your physician may be able to assist you in obtaining this information. Turn your phone OFF in health care facilities when any regulations posted in these areas instruct you to do so. Hospitals or health care facilities may be using equipment that could be sensitive to external RF energy.

Vehicles

RF signals may affect improperly installed or inadequately shielded electronic systems in motor vehicles. Check with the manufacturer or its representative regarding your vehicle. You should also consult the manufacturer of any equipment that has been added to your vehicle. Performance of electronically controlled brake and/or guidance systems can, under certain unique conditions, be subject to interference by mobile radio operation. Although the transceiver meets all requirements regarding RF emissions, you should mount the transceiver as far as possible from the guidance system and/or braking modulator box (usually located in the trunk) to minimize any interference.

Posted Facilities

Turn your phone OFF in any facility where posted notices require such as hospitals and on-board aircraft.

Aircraft

Airline regulations prohibit using your phone while in the air. Consult the local Aviation Authority for guidelines on use of the equipment on board an aircraft.

Vehicles Equipped with an Air Bag

An air bag inflates with great force. Do NOT place objects, including both installed and portable wireless equipment, in the area over the air bag or in the air bag deployment area. If in-vehicle wireless equipment is improperly installed and the air bag inflates, serious injury could result.

IsatDock DRIVE Key Features

IsatDock DRIVE is an intelligent compact docking station specifically designed for the Inmarsat IsatPhone Pro satellite handset.

IsatDock DRIVE allows the IsatPhone Pro handset to be used in a vehicle, enabling quality hands-free calls with echo cancellation and noise reduction support. IsatDock DRIVE is equipped with internal GPS, the IsatDock DRIVE provides an intelligent tracking and alert reporting system that can be easily configured to support periodic polling or emergency alert reporting.

IsatDock Design

- Slimline design
- High quality ABS plastic
- Single action insertion mechanism
- Insertion guides
- Single button release
- Key lockable
- RAM universal mounting bracket
- Integrated cable assemblies
- Robust GPS/GPS antenna connection
- Accessible control buttons
- Compact external speaker and microphone

Power

- 10-32V DC Input
- 110-240V AC plug pack, optional

Integrated Handsfree

- Superior echo cancellation
- Full duplex
- Supports privacy handset, optional accessory

Buttons on Dock

- Ringer volume up/down
- In-call volume up/down
- In-call mute
- Track button
- Alert 2-button press

Alert and Tracking

- Dedicated internal GPS receiver

TRACKING

- Periodic location messages
- SMS, SMS to e-mail
- Location message sent upon button press
- Ignition ON/OFF reporting
- Remote location polling via SMS

ALERT MODE

- 2 Button press on docking station
- Periodic alert location messages
- Supports external "panic alert" pendant or button
- Remote clearing of alert via SMS

TRACKING MESSAGE CONTENT

- Message ID#
- Header
- Latitude/Longitude
- Speed
- Direction
- Altitude

Other Key Features

- USB data
- Phone charging
- Horn alert/light integration
- Compact installation
- Privacy handset auto answer/hang up (optional)

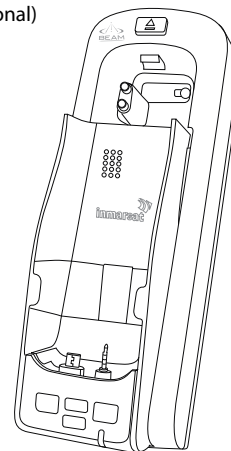

Tracking / Alert Monitoring

IsatDock DRIVE has an in-built GPS module that can provide tracking, monitoring and alert management in various land and sea based applications within various types of vehicles, vessels or fixed site locations.

The GPS module provides accurate positioning and enables tracking worldwide. The tracking function has to be configured and enabled on the IsatDock DRIVE via the Falcon. Once turned ON, tracking and alert messages can be sent to a phone number, e-mail address, LeoTrak-Online or any other tracking application via SMS.

Tracking messages can be sent from the IsatDock DRIVE in the following ways;

1. Periodic position reporting, which is preset during configuration of the IsatDock DRIVE
2. A current location position can be sent at any time by pressing the Track button on the front of the IsatDock DRIVE

The Alert mode can be activated on the IsatDock DRIVE in the following ways;

1. Use the two button press (know as the Alert button) on the front of the cradle
2. Use an external alert button/emergency push button connected to the alert loop

Once activated, alert messages will be sent to the preset destination continuously until the alert is disabled either remotely or locally on the IsatDock DRIVE unit.

Configuration using Falcon

Falcon can be downloaded from:

www.beamcommunications.com/support/drive

Follow the instructions in the downloaded application to install. Once complete, connect your PC to the USB port of the terminal and start Falcon. You can then use the application for a range of options such as:

- View the status of the terminal (signal, temperature, input voltage)
- Firmware maintenance



NOTE

Entering the firmware upgrade mode will be accompanied by a long beep followed by three short beeps.

Configuration Using Remote Commands

Configuration instructions or “Remote Commands” can be sent to the terminal via SMS, and most settings are supported that are normally accessible from Falcon. Please refer to the Falcon user manual for more information.



NOTE

Due to memory limitations it is recommended that users have no more than 20 SMS messages in their inbox. If this amount is exceeded the processing of remote commands and the ability to retrieve the messages via the Falcon tool may be compromised.

Equipment Overview

1. IsatDock DRIVE unit
2. Key Lock
3. IsatPhone Pro Eject Button
4. IsatPhone Pro
5. IsatPhone Pro docking Tray
6. Function Buttons
7. Status Indication Light
8. Power Cable Loom
 - a. Power Supply
 - b. Satellite TNC-Female Connector
 - c. GPS SMA-Female Connector
 - d. Microphone
 - e. Speaker
 - f. Alert Loop (green & brown)
Horn Alert (blue)
Radio Mute (white)
9. RAM Mounting
10. Privacy Handset Connection
11. Micro USB Data Connection

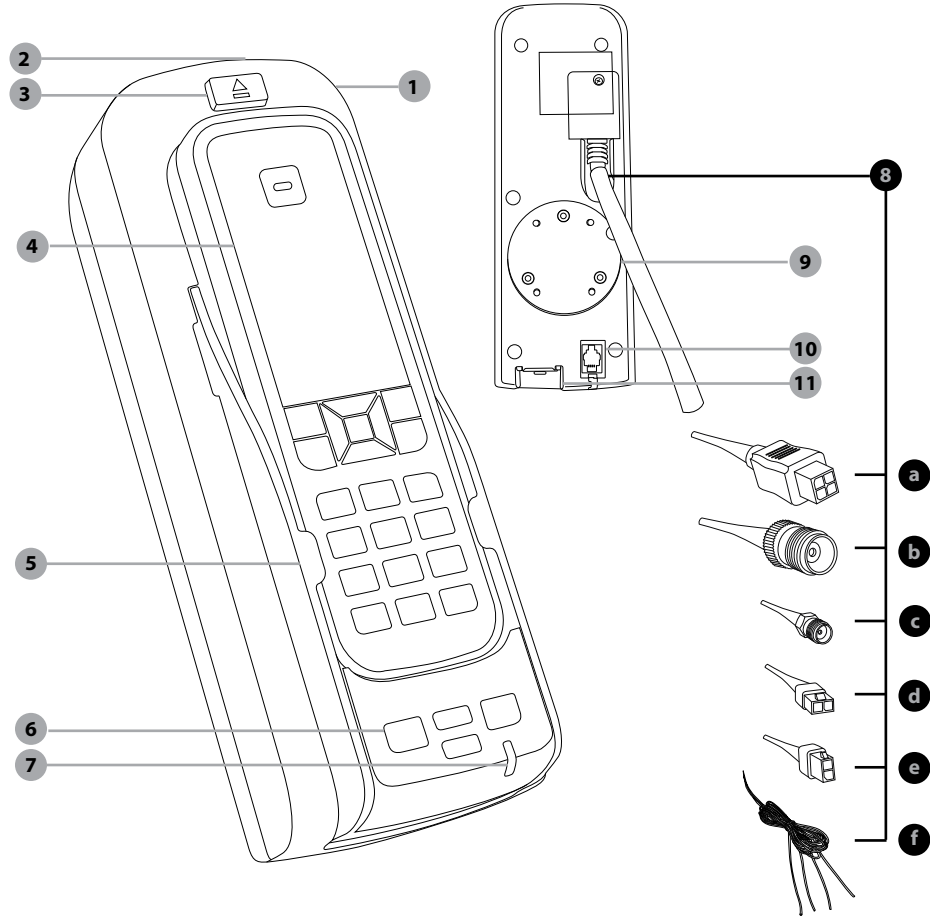

Installation Guidelines

This guide outlines the process for installing the IsatDock DRIVE in conjunction with an Inmarsat IsatPhone Pro handset.

This kit must not be used with any other device other than the Inmarsat IsatPhone Pro handset.

- Only qualified personnel should install communication equipment. If necessary, contact the vehicle manufacturer for air bag information specific to the vehicle.
- Ensure that the units are protected from dirt and moisture.
- Select an area to mount components that do not interfere with driver or passengers seating or leg space.
- Ensure that each mounting surface is strong enough to support the component being mounted to prevent the component from loosening over time.
- Mount all components securely to prevent shifting that could cause injury or could interfere with safe vehicle operation. Always use the supplied mounting hardware.
- Leave space around the units to allow cooling and ensure there are adequate clearance for cables.
- Ensure the units can be easily removed.

Routing Cables (for vehicle installations)

- Route cables so they are protected from pinching, sharp edges, and crushing.



WARNING

Air bags inflate with great force. DO NOT place objects, including communication equipment, in the area over the air bag or in the air bag deployment area. If the communication equipment is improperly installed and the air bag inflates, serious injury could result.

- Where possible, avoid routing cables above the catalytic converter.
- Use grommets wherever a cable must pass through a hole in a metal panel
- In a vehicle equipped with electronically controlled anti-skid brakes, route all cables on the opposite side of the vehicle from the braking modulator box to minimize possible interference from the phone.
- Keep all in-line connectors accessible.
- The suggested path for routing cables in vehicles without wiring troughs is alongside the drive shaft hump, under the carpet.

Guidelines for Electrical Connections

The system is designed to operate in negative ground 10 to 32 Volt DC electrical systems only. If using the DC cable lead:

- The best power connection point for the positive primary power lead is the positive terminal of the vehicle battery. Often, direct connection to the battery is inconvenient, and you may find it easier to connect the positive leads to the starter solenoid. Always select a point as close as possible to the battery.
- Connect the negative primary power leads to a good ground point on the vehicle chassis or at the battery. If you must attach the negative primary power lead directly to the negative pole of the battery, you may optionally insert a 10-amp fuse (not included) into the ground (0V) line. Failure to insert a fuse can cause equipment to overheat if a wiring fault exists.
- Many parts of a vehicle can produce electrical noise that interferes with the electrical radio system operation. The ignition system is the most common source of electrical noise interference. Before you begin installation, ensure that the ignition wiring and connections to the vehicle battery are in good working condition.

- Verify that low resistance connections are present between the battery negative terminal, the vehicle chassis, and the engine block. All wire connections should be clean and tight.
- For vehicle installation, install provided fuses into the +BATT and ignition sense (accessory) wires.



WARNING

Do not connect the IsatDock interface power cable to power the unit until the full installation is completed.

Installation Procedure

Installing the IsatDock DRIVE Cradle

Install the components in the following order. More detailed instructions can be found in the sections following.

1. Mount the IsatDock DRIVE cradle
2. Install the external Beam antenna
3. Connect the speaker and microphone to the IsatDOCK DRIVE cradle
4. Connect the privacy handset
5. Connect the DC power cable
6. Connecting Horn / Mute wires
7. Install the external alert button (optional)
8. Configure Tracking / Alert (optional)

When selecting a location for the IsatDock cradle, consider these guidelines:

- Ensure that each mounting surface is strong enough to support the cradle.
- Allow enough room so that you can easily insert the IsatPhone Pro handset in and out from the cradle.
- Ensure that the IsatDock is within cable distance of power and antenna connections
- Position the handset and cables so that it does not interfere with vehicle operation or

with driver or passenger seating or leg space.

- Ensure sufficient room is allowed for the antenna and interface cables to be routed from the rear of the IsatDock cradle.

1) Mount the IsatDock DRIVE cradle

The IsatDock DRIVE is supplied with a universal RAM® mount bracket that enables mounting to any flat surface (vertical or horizontal) within a vehicle, or other required location.

1. Attach one pivot base to the rear of the IsatDock DRIVE using the M4 screws supplied.
2. Secure the second pivot base to the location you have selected for mounting the IsatDock DRIVE.
3. Use the interconnecting step of the RAM® mount to secure the IsatDock DRIVE to the pivot base and tighten into the desired location firmly using the wing nut on the stem.

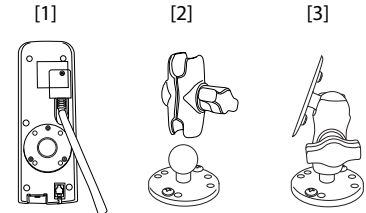

2) Install the external Beam Antenna

The antenna connections exit from the rear of the IsatDock DRIVE cradle, via the antenna loom. There are two RF connections required, the Satellite TNC – Female Connector and GPS SMA-Female connector.

1. Refer to the antennas installation guide for antenna mounting and location requirements.
2. Connect the antenna cable labelled “Inmarsat” to the IsatDock’s TNC connector
3. Connect the antenna cable labelled “GPS” to the IsatDock’s SMA connector
4. Connect the antenna cable labelled “Inmarsat” to the antenna connector labelled “ISAT” via the SMA connector.
5. Connect the antenna cable labelled “GPS” to the antenna connector labelled “GPS” via the SMA connector

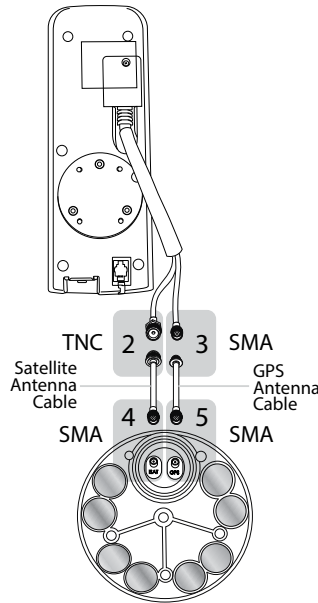

WARNING

DO NOT pull with force on the cables from the rear of the IsatDock DRIVE. Please install strain relief clamping for the antenna cables where required. Correct installation of the antenna system is a vital part of the IsatDock DRIVE system, to ensure reliable functionality, and drop-free calls.

WARNING

Changes or modifications not expressly approved by Beam Communications could void the product warranty.

WARNING

To satisfy FCC RF exposure requirements for mobile transmitting devices, a separation distance of 55 cm or more should be maintained between the antenna of this device and persons during device operation. To ensure compliance, operations at closer than this distance is not recommended.

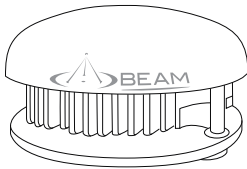

Transport Antenna
(Active)



ISD715
Magnetic Mounting



ISD720
Bolt Mounting



NOTE

Refer to the section "Antenna Installation" for more information on antenna placement and installation. Only Beam approved antenna cables should be used with all docking stations and antennas.

3) Connecting Speaker and Microphone

The IsatDock DRIVE cradle comes with an external speaker and microphone for hands-free operation.

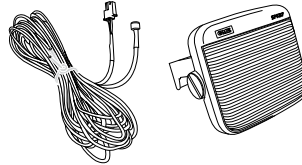

1. Mount the speaker in the appropriate location and ensure the lead is sufficient to reach the cradle.

2. Mount the microphone about 30cm away from where you normally speak and ensure the lead is sufficient to reach the cradle. By default, the audio is always on the hands-free speaker and microphone unless a privacy handset audio device is enabled.



NOTE

The speaker outputs are a Class D amplifier, which must not be connected to chassis/ground.

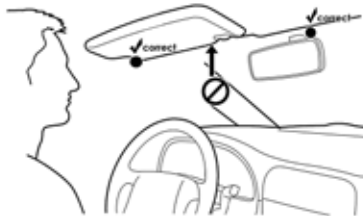

4) Connect Privacy Handset (Optional Extra)

The IsatDock DRIVE provides a RJ9 audio socket on the bottom of the docking unit, for connection to the Beam privacy handset. This provides a local handset function, conveniently mounted next to the IsatDock DRIVE cradle.

1. The Privacy Handset Kit (purchased/ordered separately) contains a mounting bracket, space plate, screws, washers and nut bolts.

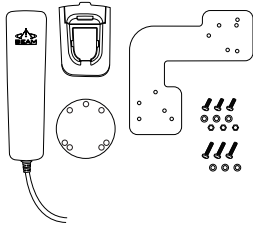

2. Mount the handset cup to the mounting plate, it can be installed to the left or right side of the dock by simply rotating the bracket. Secure the cup with the washer and nut bolt behind the bracket.

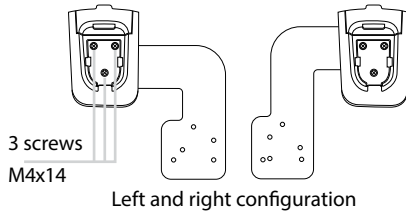

3. Mount the spacer plate and the mounting bracket to the rear of the IsatDock DRIVE, by using the longer screws provided with the kit. The original RAM® arm-bracket plate is also re-installed behind these plates.

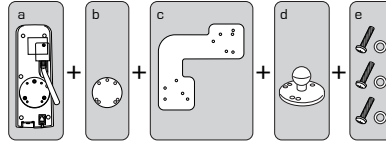

- [a] Rear of IsatDock DRIVE [b] Spacer
[c] Mounting plate [d] RAM base
[e] 3 x Mounting screws and washers

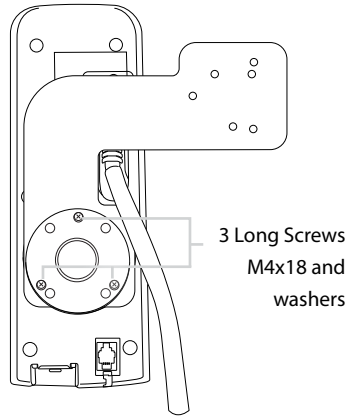

4. Plug the Privacy Handset RJ9 connector into the bottom of the docking unit, as per image below.

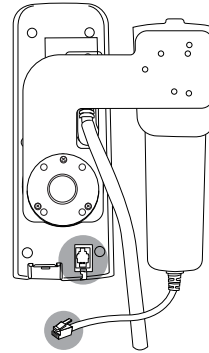
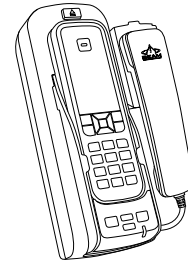

Privacy Handset mode is enabled when the handset is removed from the cup. Please ensure to re-dock the Privacy Handset when not in use.

5) Connecting DC Power Cable

The Dock can be powered from the supplied 10-32V DC power cable/lead.

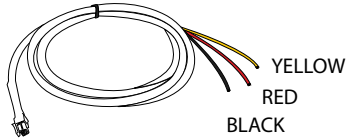

The DC power cable has three wires, RED, BLACK and YELLOW. The RED and BLACK wires are used for the power connection while the YELLOW wire can be connected to a vehicle's accessories, ignition or other similar circuits to control the ON/OFF status of the IsatDock DRIVE in synchronization with a vehicles operation. By default, the IsatDock DRIVE will stay on for 20 minutes after this input is switched off. If a call is in progress while this occurs, the IsatDock DRIVE will stay on for 20 minutes after the call is terminated. Please follow the steps to connect the DC power cable to the vehicle battery

power and the IsatDock DRIVE.

1. Route the wire end of the DC power cable to the connection point. DO NOT apply power until the following steps are completed.
2. Connect the BLACK wire to the negative terminal of the battery (10A fuse recommended) or the vehicle chassis (if negatively grounded chassis).
3. Connect the RED wire to the positive terminal of the battery. It is recommended to add the 5A fuse supplied, between them.
4. Connect the YELLOW wire to the vehicle accessory power. If the accessory power is unavailable, this may be connected to a vehicle ignition voltage. It is recommended to add a 1A fuse between them. The accessory wire enables the IsatDock DRIVE to turn on and off as the vehicle key is enabled or disabled. If this function is not required, the YELLOW wire MUST be connected to the RED wire.

5. Connect the 4-way Microfit connector on the DC power cable to the 4-way power connector on the rear cable loom of the IsatDock DRIVE.

Wiring for a Marine Application

When installed in a marine application using the DC power cable, the YELLOW wire can be wired to a suitable panel switch which will allow the IsatDock DRIVE to be turned off when not in use.

Optional ISD951 AC Plug Pack Installation

For installation with the optional ISD951 110-240 AC plug pack connect the 4-way Microfit connector from the plug pack to the 4-way power connector on the rear cable loom of the IsatDock DRIVE. In this configuration the ignition/accessory status is always ON.

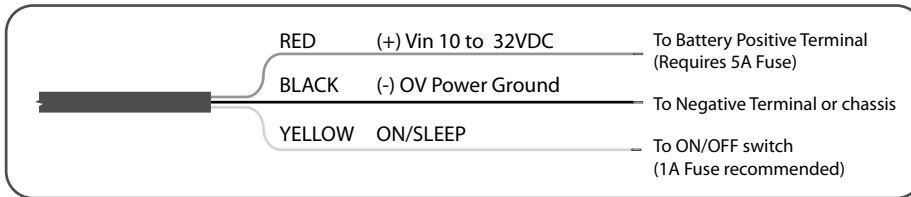
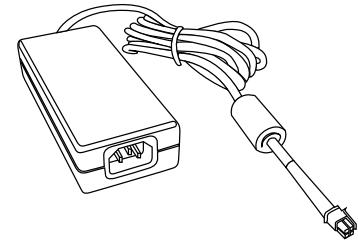

6) Connecting Horn and Mute Wires

Horn Alert Output (If required)

The IsatDock DRIVE provides a BLUE wire output on the rear cable loom for controlling an external ringer such as a vehicle horn. The horn output is an open collector output capable of sinking up to 120mA current. It CANNOT be connected to the vehicle horn directly and an automotive grade relay must be used to control the horn as shown below.

By default, it only works when the key ignition is OFF and the IsatDock DRIVE is still ON (by default, the IsatDock DRIVE will stay on for 20 minutes after the key ignition is turned OFF). This is to avoid the horn buzzing on an incoming call while the vehicle is being driven.

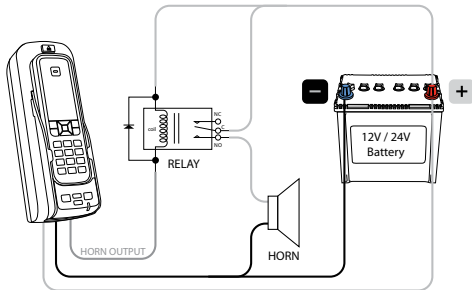

Radio Mute Feature

The entertainment mute output connects to the mute input on your car radio, if the radio includes a mute function. The entertainment mute feature automatically mutes the radio system when you place or receive a call. This feature needs to be supported by a car radio that supports in functionality.



NOTE

This output signal from the "Mute" connector sinks a maximum of 100mA (0.1A) to ground

7) Install External Alert Button (optional)

IsatDock DRIVE provides an additional cable pair from the rear cable loom, known as the standard Beam alarm loop. This provides a Normally CLOSED wire loop, which can be used to connect to any passive type of button, or relay, or reed switch in which the action breaks the loop (OPEN) to activate the alarm state.

Connect the BROWN and GREEN wires either directly to the button, or it can be extended for longer runs (up to 45 meters). This alarm loop can support multiple alarm buttons / switches – wired

in SERIES, whereby any one of these buttons will OPEN (activate) the loop when pressed.

To properly activate the alarm state, the loop needs to be OPEN for at least 2 seconds – (ie. holding down the button for 2 seconds activates the alarm).

8) Tracking & Alert Configuration (optional)

Tracking & Alert requires the setup of tracking and/or alerting messages.

Please refer to the Falcon software to enable and configure Tracking & Alert.



NOTE

If the Beam alarm loop is going to be used with an external button, remember to enable this external loop in the Falcon settings. Once enabled, the loop will be armed and activated with an open-loop condition.

To avoid false triggering, be sure to have the normally closed button wired into the alert loop, before applying power.

IsatDock DRIVE Usage

Docking & undocking the IsatPhone Pro handset

To place the IsatPro Phone into the docking unit, both the 'covers' on the external antenna connectors and the USB/Audio connectors need to be opened.

1. The antenna 'cover' must be placed at 90 degrees to the antenna connector cavity and run parallel to the top edge of the phone.
2. The 'cover' in the base of the phone should be in the a 90 degree opened position.

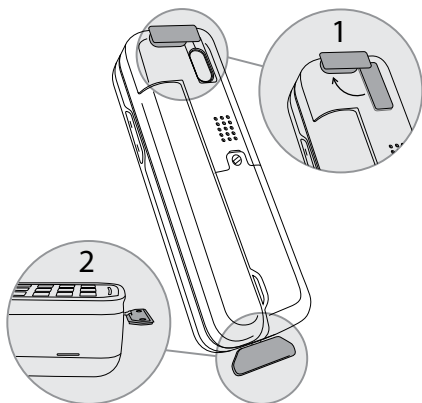

3. To dock the handset, align the IsatPhone Pro with the phone tray and slide the handset down until it seats flush to the bottom of the tray. Swing the phone down into the cradle by applying pressure to the top of the handset. An audible 'click' is heard when the phone is in the docked position.

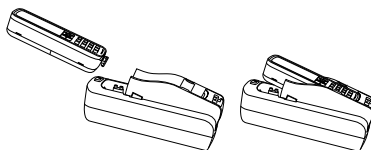

4. To remove the handset from the cradle, press the EJECT button at the top of the docking station. The dock will swing out and the handset can be removed.

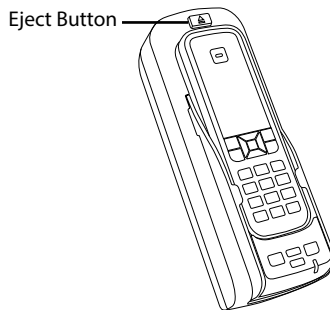

IMPORTANT:

Before docking the IsatPhone Pro to the docking station, check that the USB cover is open, able to swing free (without putting it in a "locked open" position as illustrated in 'A') and ready for docking at a 90-95 degree angle as shown on image 'B'. If you have a gap similar to image 'C', please do not force the IsatPhone Pro down. This can damage the USB connector and void warranty

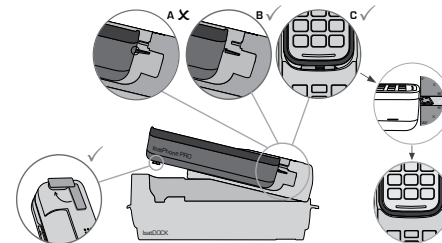

Operation of the IsatPhone Pro

Prepare the Inmarsat IsatPhone Pro

Ensure that the IsatPhone Pro Handset has the latest compatible firmware installed. For more information visit:

www.beamcommunications.com/support/drive

Starting Up

1. Retract the antenna on the IsatPhone Pro handset.
2. Place the IsatPhone Pro as per instructions “Docking & Undocking” on page 21.
3. Turn vehicle ignition on. The IsatPhone Pro will automatically power and the handset will then start to initialise followed by a 3 tone rising beep when a successful connection has been made between the docking station and the IsatPhone Pro.
4. Wait for the IsatPhone Pro handset to register on the Inmarsat network. The STATUS LED on the docking station will turn green when a successful registration has taken place.
5. You are now ready to make and receive calls.



NOTE:

- 1) *If the IsatPhone Pro is removed from the dock during a call, the call will drop out during this transition.*
- 2) *One common cause for connection failure is a flat IsatPhone Pro battery which prevents the IsatPhone from turning ON. In these instances the docking station will attempt to charge the IsatPhone Pro handset while it is switched OFF, until enough charge is present for the IsatPhone Pro to turn ON. This charging period can take up to 20 minutes depending on how flat the battery.*

Pro handset

The IsatDock DRIVE provides charging power to the IsatPhone Pro handset via its USB connector. The IsatPhone Pro battery is a lithium-ion cell which has a safety temperature range whilst charging. This range is from 0-45°C (32-113 °F). Due to the increased heating effects on the IsatPhone Pro handset whilst it is docked and being charged, it is ideal for the ambient temperature to be at least 18 degrees below the 45°C upper limit for the handset to charge the battery whilst docked. If the battery temperature

exceeds this limit, then the IsatPhone Pro may cease charging until the temperature is reduced.

Placing Voice Calls

Bluetooth® calls via IsatPhone Pro

The IsatDock DRIVE allows for Bluetooth audio calls to be placed via the IsatPhone Pro handset while docked. Consult the IsatPhone Pro manual for further information on pairing and Bluetooth discovery setup.

Hands-Free Phone Call – Mobile Originating

1. Dial the number (using the full country codes) on the IsatPhone Pro handset keypad whilst docked. Press the GREEN key to start the connection.
2. A message will display on the IsatPhone Pro handset to indicate the call is progressing.

Options:

- A. During the call, you may transfer the call to the optional privacy handset by taking the privacy handset out of its cup. This automatically directs the call audio to the privacy handset.
- B. To return the call back to hands-free mode, place the privacy handset back in its cup.

Hands-Free Phone Call – Mobile Terminating

Make a call from your landline phone or mobile phone to the IsatPhone Pro handset. You need to know the phone number of the SIM card used in the IsatPhone Pro handset.

1. The IsatDock DRIVE external speaker will ring according to the ringer setting of the IsatPhone Pro.
2. Answer the call by pressing the GREEN key on the IsatPhone Pro handset.

Once the call is in progress, options A and B from “Hands-free Phone Call – Mobile Originating” section are also applicable.

Privacy Handset Use (Optional Accessory)

Privacy handset Phone Call - Mobile Originating

1. Remove the privacy handset from its cup
2. Dial using the full Inmarsat dialing sequence eg. 00 country code and telephone number on the IsatPhone Pro keypad whilst docked. Press the GREEN button to start the connection.
3. A message is displayed on the IsatPhone Pro to indicate a call is in progress.
4. Once the call is connected, the STATUS LED will flash to indicate a call is in progress.

5. Press the RED key on the IsatPhone Pro handset to terminate the call.

Privacy Handset Phone Call - Mobile Terminating

1. Answer the incoming call by un-cupping the privacy handset from its cup.
2. Press the RED key on the IsatPhone Pro handset or return the privacy handset to its cup to terminate the call.

Mute Mode

Mute functionality

The mute function of the IsatDock DRIVE allows the user to mute the uplink microphone audio on the privacy handset and/or external hands-free microphone.

1. During a call, Press the Mute button on the face of the IsatDock DRIVE, a RED LED will illuminate the Mute button to confirm that the IsatDock DRIVE is muted.
2. To exit the mute mode, press the mute button once.

USB Driver Installation

The IsatDock DRIVE USB data port requires an interface driver to be installed on the user’s computer prior to undertaking data communication. This driver supports the

following operating systems:

Windows XP (SP3 or above), Windows Vista & Windows 7.

You can download the Windows driver for the IsatDock from

www.beamcommunications.com/support/driver

Tracking and Alert Operations

Enable Tracking & Alert

The Tracking & Alert function is not enabled by default and it has to be configured and enabled using the Falcon software via the micro-USB connection to the IsatDock DRIVE.

This option can be activated through the below link as required:

www.beamcommunications.com/support/drive

Various configuration options are available to the user in the Falcon. The message delivery method is also set using the Falcon. Please refer to the Falcon User Guide for more details on how to configure and enable the Tracking & Alert function on the IsatPhone Pro.

Send Tracking Position

In order to send a tracking message, the following condition must be fulfilled.

1. The GPS receiver has acquired enough satellite signals and navigational data to calculate a positional solution (fix).
2. The IsatPhone Pro handset is registered with the GSPS network.
3. Tracking is configured and enabled via the Falcon.

The Track LED will stay off if the Tracking function is disabled. It will turn solid GREEN if all of the above conditions are satisfied. Otherwise, it will flash in GREEN if the Tracking function is enabled but no GPS fix and/or GSPS registration. To manually send a tracking message of the current location

- A. Apply a single press to the Track button.
A single beep will sound (if configured in the Falcon).

Activate Alert Mode

Alert mode can be activated by one of the following two methods:









1. Press and hold both the Track and Mute buttons together for 2 seconds. A single beep will sound (if configured in the Falcon).
2. If enabled by the Falcon, press the external panic button (optionally wired into the Alert Loop wires).

Once triggered into the Alert mode, the Track LED turns RED. The message then attempts to be sent. The Track LED will flash in RED when the alert message is sent. (Rate: 1.5sec off, 1.5sec on, etc). The Track LED will flash in YELLOW when the alert message is acknowledged by a remote host. (Rate: 1sec off, 4sec on, etc)

Clearing an Alert

To clear the alert mode press and hold the Track button for seven seconds. A single beep will sound, and the LED will show re-armed state (GREEN).

IsatDock DRIVE Front Panel

Location	Button Mode	Action	LED/Sound
	Mute Press on/off	In a Call: Mute the microphone (uplink) on the privacy handset (optional accessory) if connected to cradle.	LED turns RED - Muted LED turns OFF - Not muted
 OR 	Up/Down	In a Call: Increase/decrease volume on the external speaker or privacy handset (optional accessory) if connected to cradle. Out of Call: Increase/decrease volume of incoming ring tone on the external speaker.	Audio will sound louder/quieter in privacy handset with each press. A beep will sound indicating the increased/decreased ring tone volume.
	Single Press (1 second)	In Tracking Mode*: Send a tracking message to the pre-configured destination	A beep will sound to indicate that a tracking message is to be sent [†]
	Single Press (7 seconds)	In Alert/Emergency Mode*: Clear the alert/emergency mode and return to the Tracking mode*.	LED changes from RED/YELLOW (solid or flashing) to GREEN [†]
 + 	Two button press (2 seconds)	In Tracking Mode*: Activate the Alert/Emergency mode.	A beep will sound indicating alert/emergency mode is activated [†] LED changes from GREEN to solid RED. LED changes to flashing RED once the alert has been sent. LED will change to slow flashing YELLOW once the remote server has acknowledged receiving the alert.
 + 	Brightness dual button simultaneous press	Out of Call: Enter LED brightness change mode. Press UP and DOWN arrows to vary intensity. Mode will automatically exit after 5 seconds after the last button press.	All LED's will change to WHITE and a single beep will sound when entering brightness change mode. A short double beep will sound when exiting change mode.

* This action is optional, only when the Tracking Mode for your IsatDock DRIVE is configured and activated.

[†] A beep will only sound if audible alerts are enabled in the Falcon

IsatDock DRIVE Buttons/LED lights

TRACK	GREEN	RED	YELLOW	WHITE/OFF
ILLUMINATED	Tracking enabled, GPS fix acquired.	Alert mode activated	N/A	Tracking and alert disabled
FLASHING	No GPS fix	Alert message sent	Alert message acknowledged by remote party/server	N/A
MUTE	GREEN	RED	YELLOW	WHITE/OFF
ILLUMINATED	N/A	Outgoing audio is muted	N/A	Outgoing audio is not muted
LED STATUS	GREEN	RED	YELLOW	WHITE/OFF
ILLUMINATED	Handset registered and able to make a call	Handset not registered/ no signal and cannot make or receive calls	N/A	N/A
FLASHING	Call in Progress	N/A	N/A	N/A
ALTERNATING	N/A	Error detected in communicating with IsatPhone Pro handset. Flashing RED/BLUE	N/A	N/A

1. Mute
2. Track
3. Up & Down
4. LED STATUS

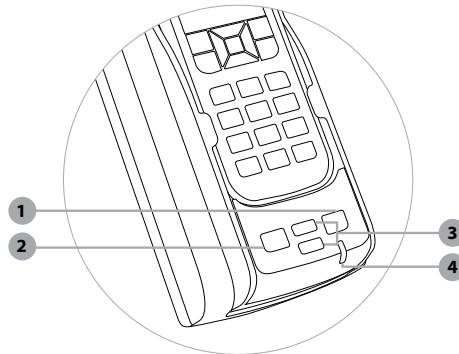

Assuring Quality of Service

There are conditions that can compromise the quality of the service you may receive. These include:

- Obstructions
- Cabling
- RF Interference

Obstructions

Nearby tall buildings or similar structures, heavily leafed trees and mountains can all degrade performance as they block the signal between the antenna and the satellites.

Inmarsat performance is immune from natural environments such as clouds, fog, rain, snow, wind and smoke.

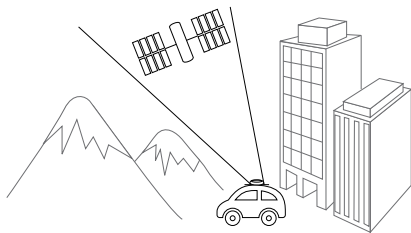

Cabling

Using an externally mounted antenna provides an ideal solution for many applications. It is very important that both the antenna cabling and antenna are Beam approved products. Always ensure all RF connectors are screwed together firmly and ensure there are no sharp bends in the cabling between the docking station and the antenna.

RF Interference

All wireless devices, including satellite telephones, are susceptible to RF (radio frequency) interference from other electronic devices. This problem is more evident when numerous antennas and broadcasting devices are located within close proximity to each other.

Symptoms of RF Interference

Symptoms of RF interference often resemble those that arise when an antenna is being operated with an obstructed view of the sky. Some of these symptoms include; erratic or no signal strength indication dropped calls or warbled or otherwise distorted voice. These symptoms may be intermittent or persistent, depending largely on the interference source, its distance, strength and frequency relative to the antenna.

Mitigation of RF Interference

Service degradation due to RF interference can be significantly improved by:

- Increasing the distance and moving the antenna off axis from the source of the interference, and
- Using an external band pass filter and an external antenna.



WARNING

Failure to use BEAM approved antenna cables will result in degraded performance and may damage the Docking Station. This will void the product warranty.

Specification Summary

Electrical & Environmental Specifications - IsatDock DRIVE

Average Power Consumption Current @ 12V	Average	Watts
Power w/o IsatPhone Pro	130mA	1.6W
Standby + Charging	360mA	4.3W
Transmit + Charging	875mA	10.5W
Sleep Mode	5mA	60mW
Peak Current	3.5A	42W
Physical Specifications		
Dimensions	230 x 84 x 80 (mm)	9.1 x 3.3 x 3.2 (inches)
Weight - dock	670g	1.47lbs
Total Kit Weight	1.67kg	3.68lbs
Environmental Specifications		
Operating Range	-30°C to +70°C	-22°F to +158°F
Storage	-35°C to +85°C	-31°F to +185°F
Battery Charging Temp*	0°C to +45°C	+32°F to 113°F
Humidity	<= 75% RH	
GPS Module (internal)		
Channels	14 tracking, 51 channel acquiring	
Update Rate	1Hz	
Accuracy	Position 2.5m CEP, Velocity 0.1m/s, Timing 300ns	
Acquisition TTFF	Cold 29sec, Hot 1sec	

Sensitivity	-161 dBm
Operational Limits	Altitude 18000m, Velocity 515m/s
Dynamics	4G
I/O Alarm/Alert	
Alert Button in-built	Two button press
1 x alarm loop	Bare wire - "Normally closed" loop IN to OUT
Track	In-built - single key press
Connectors / Interfaces	
BEAM Antenna	TNC-Female
GPS Antenna	SMA-Female
10-32V DC	4-way microFit (AC/DC adaptor, or DC lead)
Privacy Handset Port	RJ9 connector
Speaker	2-way microFit / Class D, >3W 8ohm
Microphone	2-way microFit / 2.5V DC bias electret
Certifications	
Inmarsat Type Approval, FCC, CE Compliance, Electrical Safety, RoHS, Industry Canada, C-Tick, EMC Compliance	
Accessories	
ISD715 - Transport Magnetic Antenna (Active)	
ISD720 - Transport Bolt Antenna (Active)	
ISD932 - 6m SMA/TNC cable kit (Active)	
ISD933 - 13m SMA/TNC cable kit (Active)	
ISD934 - 18m SMA/TNC cable kit (Active)	
ISD935 - 30m cable kit (Active)	

ISD938 - 40m cable kit (Active)	
ISD938 - 50m cable kit (Active)	
ISD942 - 60m cable kit (Active)	
ISD943 - 70m cable kit (Active)	
ISD944 - 80m cable kit (Active)	
ISD945 - 90m cable kit (Active)	
ISD946 - 100m cable kit (Active)	
ISD955 - Privacy Handset	
RST410 - Man Down Kit	
RST055 - UPS Battery Pack	
ISD951 - 110-240v AC plug pack	
Kit Contents	
IsatDock DRIVE	
10-32V DC power cable / Fuse kit	
Speaker	
Microphone	
Universal mounting bracket (RAM)	
Handset locking key	
User manual	
Quick start guide	



NOTE:

Specifications are subject to change without notice.

** It is ideal for the ambient temperature to be approximately 18 degrees below the 45°C upper limit for the handset to charge the battery whilst docked.*

(1) Physical Dimensions - Drive Dock

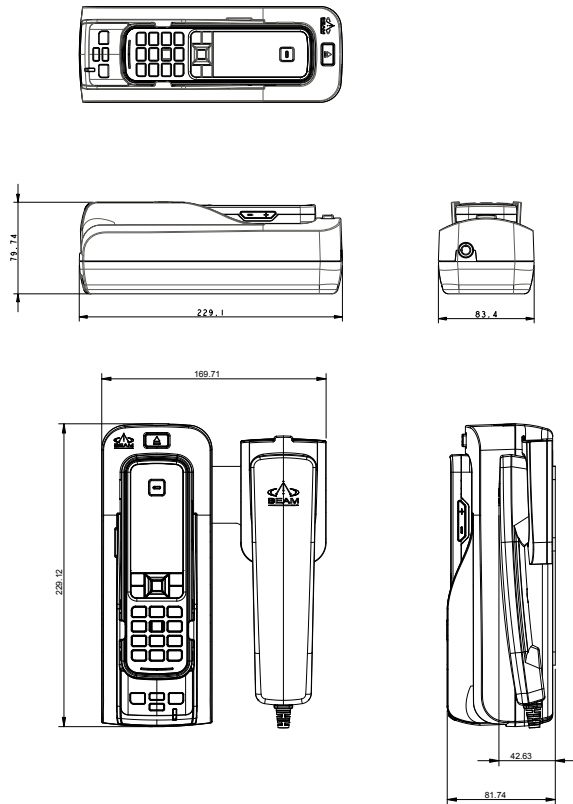

(2) Physical Dimensions - Privacy Handset

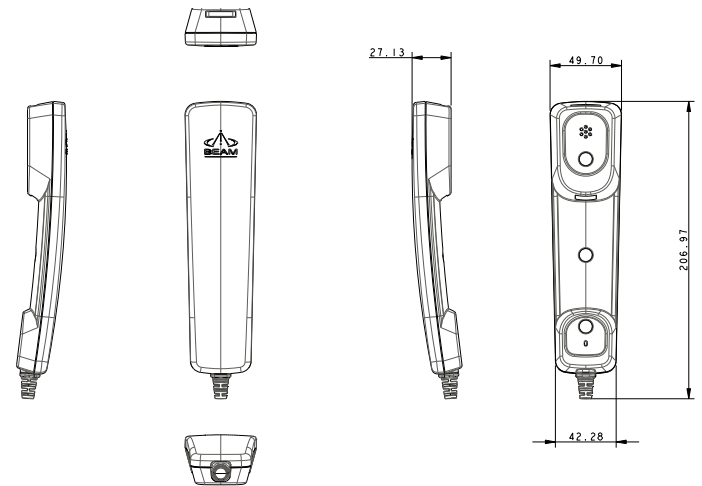

Trouble Shooting

This chapter provides information to help you troubleshoot problems you may encounter while running the IsatDock DRIVE.

Q1	How do I know if my IsatPhone Pro is registered on the Inmarsat network?
A	The STATUS LED of the docking station will change to GREEN when the handset is registered and able to make calls on the network. The IsatPhone Pro will also indicate "Inmarsat" in the top left corner of the screen display.
Q2	The handset and docking station turn's OFF every 20minutes?
A	Ensure the Ignition/Accessories wire is connected to power. If this is not connected, or connected to ground the docking station will go into sleep mode after 20 minutes by default.
Q3	No power on IsatDock.
A	Check power is connected to the interface unit. If applicable, check the vehicle ignition is in ACC or IGN or ON position. Ensure the Connector cable to the IsatDock is firmly fitted. Check all the connection cables to and from the IsatDock.

Q4	The signal bars are low or fluctuating and call quality is poor.
A	Ensure all antenna connectors are tight. The antenna is operating in a location that it can see the satellite and there are no obstructions. Beam certified antenna cabling is being used and there are no sharp bends or cuts in the cable. If using a fixed passive antenna, ensure it is orientated correctly and pointing at the satellite.
Q5	I am looking for the latest manuals and support information on the docking station ?
A	Visit: www.beamcommunications.com/support
Q6	Dropped calls
A	Due to a satellite network when you are in motion the satellite signal may become obstructed (such as buildings, bridges, tunnels, larger vehicles). Check the antenna connection. Ensure the antenna cable has not been damaged. Ensure that only approved antenna cable has been used. Refer to Antenna Install Guide on Beam website support.

Q7	Party B cannot hear your voice.
A	Privacy Handset must be docked in its cup when not in use. Check that MUTE is not ON (indicated by turning RED) Check the signal strength on the handset. Ensure the Handset connector at the base of the IsatPhone Pro is not obstructed and there is no dust or foreign objects in the connector socket.
Q8	The docking station appears to be turning ON/OFF and the handset is not registering.
A	Ensure the power supply can provide at least 3.5A at 12volts. If power is being supplied from a battery, ensure the connections are tight and the contacts are clean.

Beam Warranty Terms & Conditions

Beam Communications gives this express warranty (along with extended warranty endorsements, where applicable) in lieu of all other warranties, express or implied, including (without limitation), warranties of merchantability and fitness for a particular purpose. This constitutes our sole warranty and obligation with regard to our products as well as the Customer's sole remedy.

Beam Communications expressly disclaims all liability and responsibility for any special, indirect or consequential damages or any further loss of any kind whatsoever resulting from the use of our product(s). The Customer's sole and exclusive remedy and the limit of Beam's liability for any loss whatsoever, shall not exceed the purchase price paid by the Customer for the product to which a claim is made.

All products manufactured by Beam Communications are warranted to be free from defects in material and workmanship in accordance with and subject to the following terms and conditions:

1. This warranty is limited to the original Customer only. It cannot be transferred or assigned to third parties unless the intent to transfer to a third party is expressly indicated in a purchase order and/or warranty-processing arrangements have been agreed upon in writing by Beam.
2. Beam Communications does not warrant any installation, maintenance or service of the Products not performed by Beam, nor does it warrant the use of Products with unapproved ancillary products.

3. Beam Communications will correct any defects in material or workmanship of products manufactured by Beam which appear within twelve (12) months, from the date of shipment by Beam Communications to the Customer. Exception to a 12 months warranty are:

- Units that they do not carry a transceiver (24 months warranty)
- Accessories (3 months warranty)

Please note that antennas and products not manufactured by Beam (like; NAL Shout Nano, Man down Kit, RST970, 9522B and 9602) also come with a 12 month warranty. Beam Communications will repair or replace, at our option, any defective product, provided that our analysis and/or inspection disclose that such defects developed under normal and proper use.

4. This warranty does not extend to goods subjected to liquid or particulate ingress, extreme humidity, misuse, neglect, accident or improper installation, or to maintenance or repair of products that have been altered or repaired by anyone except Beam Communications unless otherwise stated in writing. If a product has been tampered with (e.g. warranty seal has been removed, wrong cable has been used with an antenna), the warranty will be void.
5. The warranty is a return-to-base warranty and freight is paid by the sender.
6. A charge of USD\$195.00 including return freight will

be made for testing returned product which is not defective or is found to be defective as the result of improper use, maintenance or neglect.

7. Beam Communications will not accept responsibility for any invoiced goods or services that are not covered by a Beam Communications written purchase order. Under no circumstances does Beam Communications agree to pay for labor or other related expenses associated with the troubleshooting and/or repair of our product without prior specific written authorization.
8. Information in our descriptive literature is based on product specifications that are current at the time of publication. Product specifications, designs and descriptive literature are subject to change as improvements are introduced. Although we announce changes as they occur, we cannot guarantee notification to every Customer. Beam Communications warrants delivered product to conform to the most current specifications, designs and descriptive literature.
9. This warranty policy may be expanded or limited, for particular categories of products or Customers, by information sheets published as deemed appropriate by Beam Communications. In particular, the warranty for third party Products is that of the third party and not Beams warranty.

Beam Communications

GLOBAL HEAD OFFICE

Tel: +61 3 8588 4500 Fax: +61 3 9560 9055

AMERICAS

Tel: +1 800 250 5819 (USA toll free) Fax: +1 888 972 8037

EUROPE

Tel: +44 208 144 1405 Fax: +44 208 289 3542

Info: info@beamcommunications.com

Support: support@beamcommunications.com



www.beamcommunications.com